

**SIEMENS**  
*Ingenuity for life*

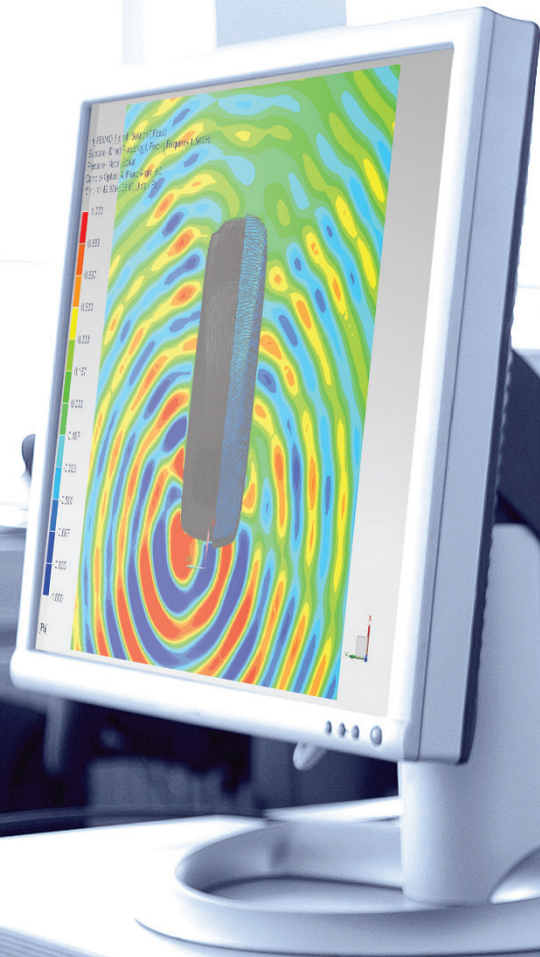

Siemens Digital Industries Software

## Simcenter 3D for acoustics simulation

Optimizing the sound quality of products

[siemens.com/simcenter3d](https://www.siemens.com/simcenter3d)

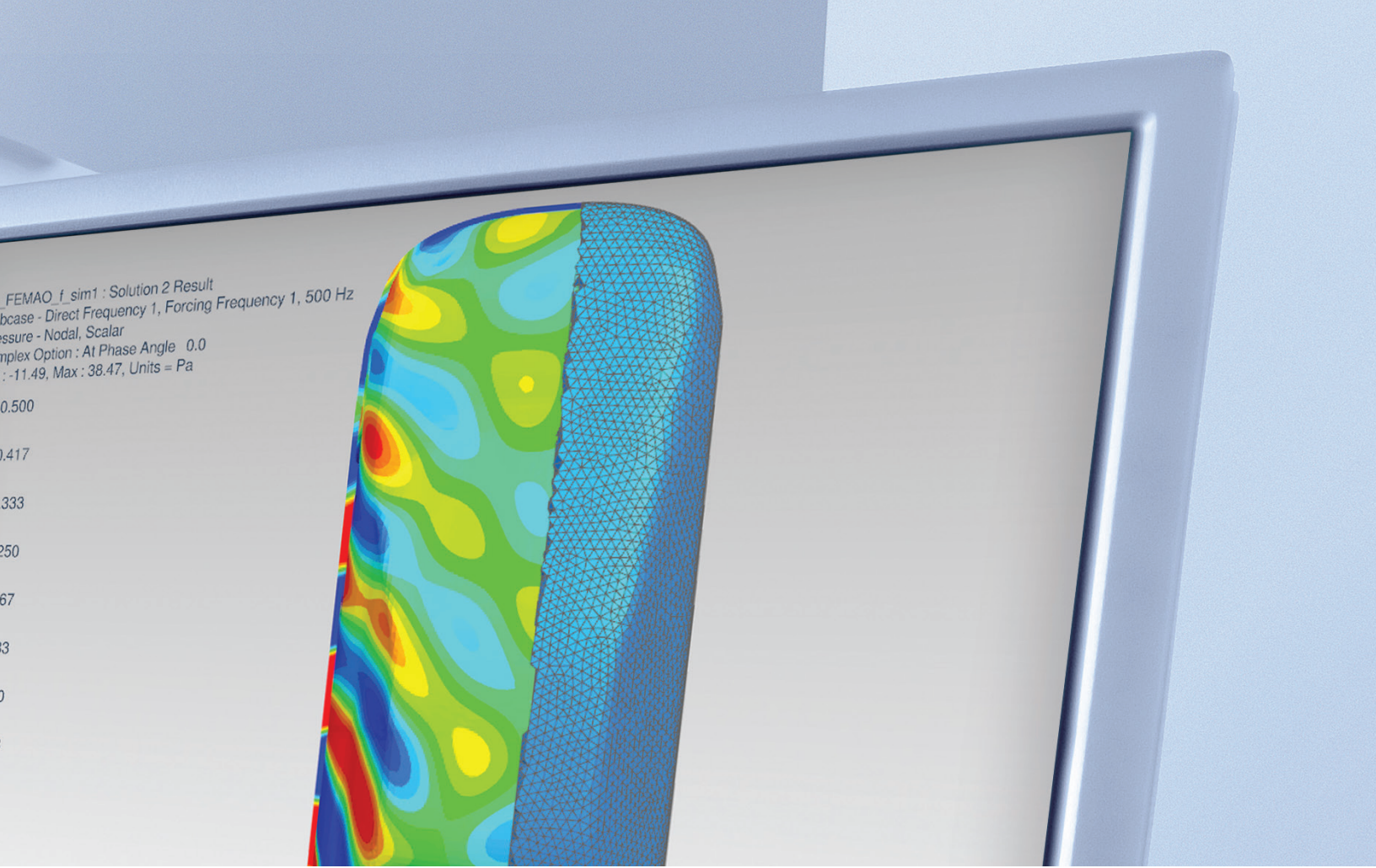

FEMAO\_f\_sim1 : Solution 2 Result  
bcase - Direct Frequency 1, Forcing Frequency 1, 500 Hz  
Pressure - Nodal, Scalar  
Complex Option : At Phase Angle 0.0  
Min : -11.49, Max : 38.47, Units = Pa

### Solution benefits

- Accelerate creation of acoustic simulation model from complex geometries, either from structural mesh model, CAD geometry or from scratch
- Use fast and efficient FEM/BEM solvers to more rapidly deliver acoustic computations
- Efficiently solve acoustics, vibro-acoustics and flow-induced noise problems from a single interface
- Simulate acoustic performance for interior, exterior or mixed interior-exterior problems
- Speed up multiple RPM acoustic computations involving engines, gearboxes and rotating components
- Perform realistic acoustic simulation: anechoic boundary condition, porous (rigid and limp frames) trim materials, acoustic source, ray noise and more

Simcenter™ 3D software offers a comprehensive solution to minimize noise and optimize the sound quality of products. Dedicated acoustic modeling capabilities, efficient solvers and easy-to-interpret visualization tools allow you to quickly gain insight into a design's acoustic performance for uncoupled acoustics, coupled vibro-acoustics and aero-acoustic applications.

### Accelerate acoustic meshing and modeling

Advanced features, such as surface wrapping, convex meshing, mesh thickening and the ability to create hybrid (hexa-tetra) meshes, help you accelerate acoustic meshing processes more than traditional preprocessors. The availability of various material models for both structure and fluid and the wide variety of structural and acoustic boundary conditions and loads allow you to efficiently set up your analysis.

### Deliver high-fidelity vibro-acoustic simulations in the most efficient way

Simcenter 3D increases the realism in your simulations by providing support for loads or source creation from test data and predecessor multi-body or computational fluid dynamics (CFD) simulations. Simcenter Nastran®

# Simcenter 3D for acoustics simulation

software is used to rapidly solve complex interior and exterior acoustics problems thanks to key features like automatically matched layer (AML) and finite element adaptive order (FEMAO) technology, which allow you to use small fluid meshes with an optimal number of degrees-of-freedom (DOF) per frequency.

## Faster design-analysis iterations with CAD-CAE-test associativity

Simcenter 3D seamlessly links to computer-aided design (CAD), computer-aided engineering (CAE) and even test data. Any design modification can be easily introduced to the structural and/or acoustic model, eliminating multiple conversions between file formats and recreating models.

## Gain instantaneous insight with acoustic-specific postprocessing

Simcenter 3D provides easy-to-interpret and intuitive postprocessing tools to investigate noise as sound pressure level (SPL), acoustic power or directivity. Path, modal and panel contribution analysis helps to rapidly identify the important noise sources and their propagation.

## Providing a platform for multidiscipline simulation

The Simcenter 3D acoustics solution is part of a larger, integrated multidiscipline simulation environment with the Simcenter 3D Engineering Desktop at the core for centralized pre- and postprocessing for all Simcenter 3D solutions. This integrated environment helps you to achieve faster CAE processes and streamline multidiscipline simulations that integrate acoustics and other disciplines like, gear whine analysis from motion solutions, or NVH and vibro-acoustics analyses that require structural or flow-induced loads.

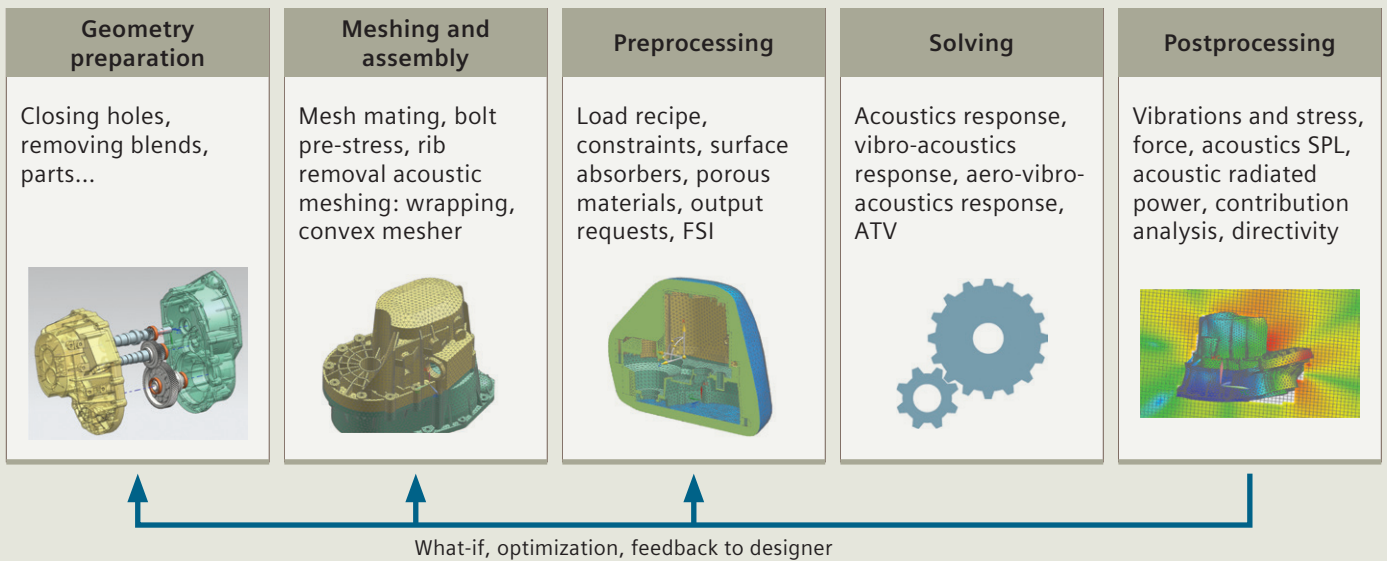
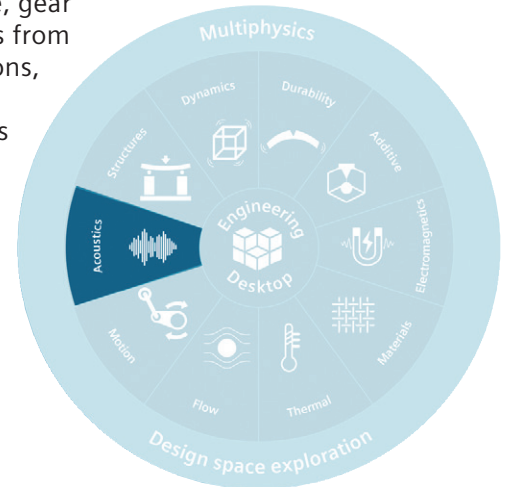

### Industry applications

Since noise can impact health, and a quiet product is often perceived as higher in quality, companies are adopting efficient processes and tools to optimize the noise performance of their products.

### Aerospace and defense

With Simcenter 3D, aviation engineers can predict cabin noise generated by turbulent boundary layers (TBL) on the fuselage or by aero-acoustic noise coming from the environmental control system (ECS). Exterior noise can be tackled using high-end boundary element method (BEM) and FEM solvers. Spacecraft engineers can reduce the risk of their acoustic verification tests by evaluating them virtually in Simcenter 3D.

### Automotive and transportation

During vehicle development and improvement programs, the capabilities of Simcenter 3D can deliver noise, vibration and harshness (NVH) engineers with valuable insight into acoustic, vibro-acoustics and aero-acoustic noise contributions in the vehicle cabin and exterior environment.

### Consumer goods

Building powerful, high-quality speakers, silent vacuum cleaners and washing machines and other noise-free consumer goods requires advanced noise engineering and sound characterization features provided by Simcenter 3D.

### Industrial machinery

Simcenter 3D acoustic modules provide the necessary features to evaluate machine-radiated noise, including capturing the effect of encapsulations with sound treatments.

### Marine

Acoustic features of Simcenter 3D can be used to study complex underwater radiation from ship hulls, propellers and submarine hull reflections of sonar waves.

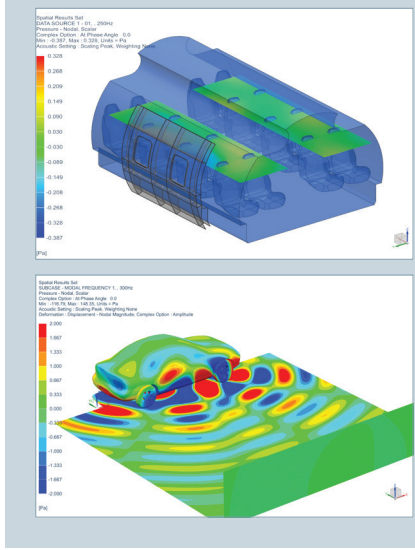
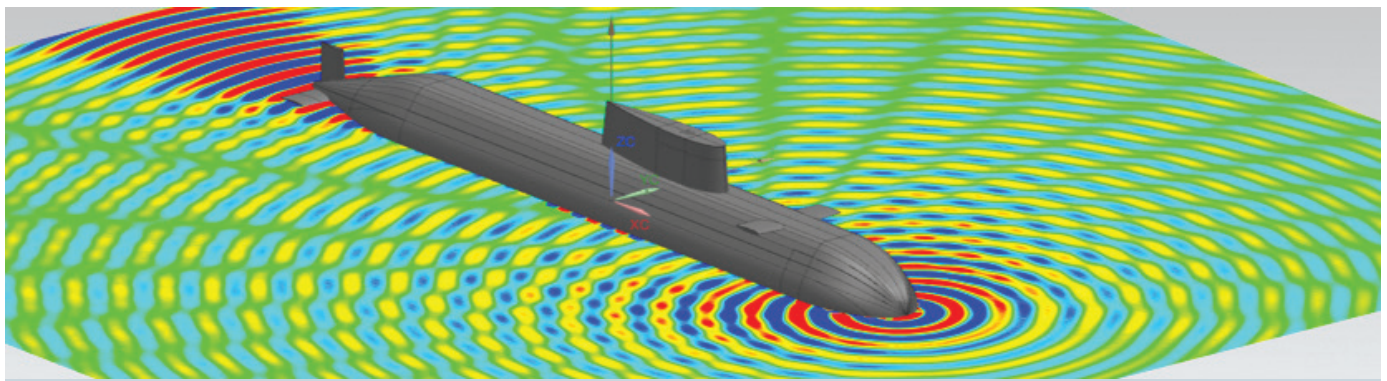

- Structural acoustics
- Aero-vibro-acoustics
- Component noise radiation
- Full vehicle scattering
- Cabin vibro-acoustics
- Transmission loss
- Room acoustics
- FEM/BEM/Ray acoustics

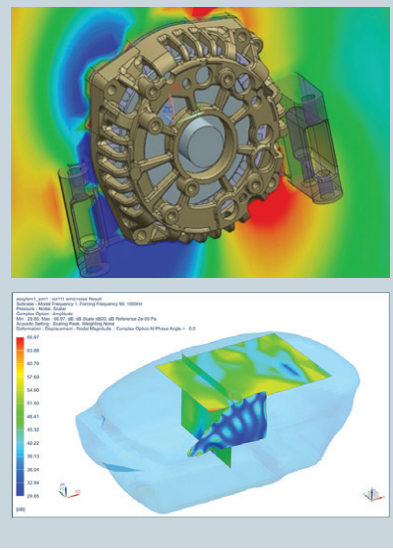

# Simcenter 3D Meshing for Acoustics

Simcenter 3D Meshing for Acoustics software helps you create meshes for FEM and BEM acoustic analysis. The module provides user-friendly, leading-edge functionalities to create an acoustic fluid mesh, both for interior as well as exterior acoustic applications, starting from an existing structural mesh or CAD geometry.

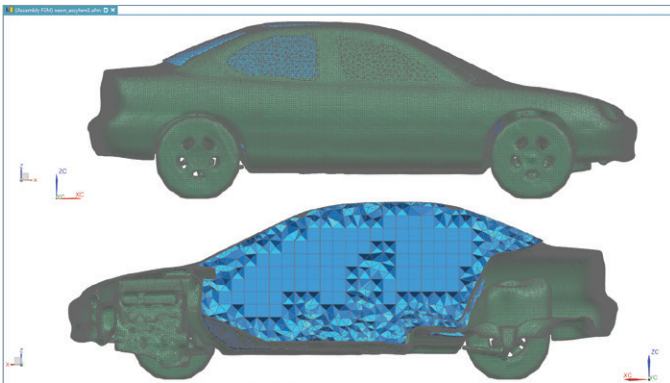

## Module benefits

- Start from a structural FEM model or CAD geometry
- Accelerate the acoustic meshing process for complex geometries

## Key features

- Hybrid mesh and polygon-based coarsening, hole-filling and rib-removal tools
- Interior and exterior surface-wrapping technology based on input of CAD or CAE model
- Easy creation of convex outer boundary surface to construct FEM meshes for exterior acoustics
- Hybrid hex a dominant hexa and tetra mesher for fluid volumes facilitating efficient solving
- Shell mesh thickening (reverse of mid-surfacing) to derive the boundary surfaces of fluid cavities, which is useful for muffler and other fluid FEM meshes

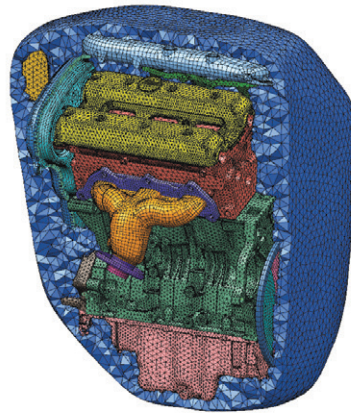

# Simcenter Nastran Advanced Acoustics

Simcenter Nastran Advanced Acoustics software provides support for standard loads and boundary conditions, and key technologies like AML and FEMAO, to rapidly resolve acoustic simulations. It is well suited to study the acoustic radiation of components and pass-by noise of full vehicles, transmission loss of duct systems like intakes and exhausts or mufflers, and transmission loss of panels.

## Module benefits

- Performs vibro-acoustic (SOL108/SOL111) simulations for interior or exterior noise
- Study exterior acoustics with lean FEM models thanks to embedded AML technology
- Efficiently simulate broadband acoustic problems using the adaptive FEMAO solver

## Key features

- Support standard loads and boundary conditions, as well as specific acoustic boundary conditions like duct modes and acoustic diffuse field (random) loads
- Pressure loads on structural surfaces from other acoustic or CFD analysis
- Porous and temperature-dependent fluid materials, mean convective flow effects, frequency-dependent surface impedance and transfer admittance between pairs of surfaces
- Compute sound pressure, intensity and power for virtual microphones located inside or outside the meshed fluid volume

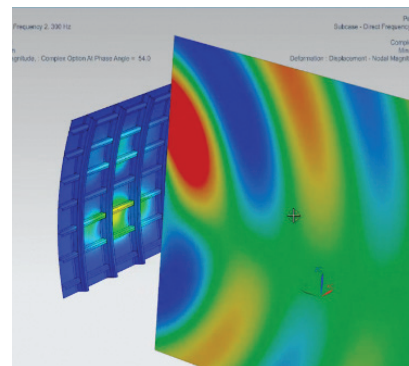
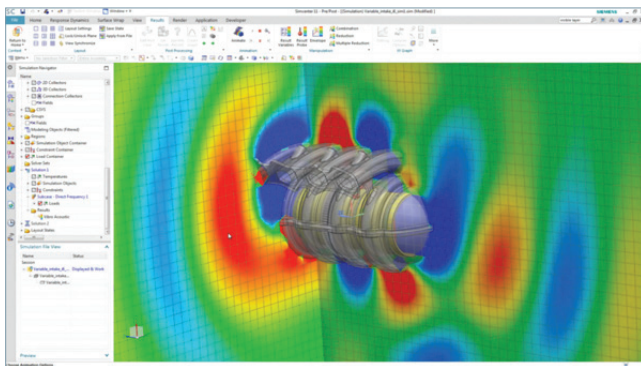
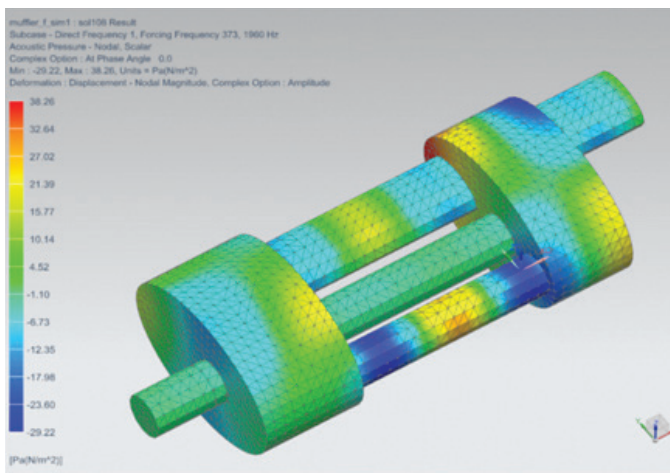

# Simcenter 3D Acoustic Transfer Vector

Simcenter 3D Acoustic Transfer Vector software supports computing the acoustic transfer vector (ATV), expressing the sensitivity of the pressure response at a virtual microphone per-unit normal velocity at field points on a radiating surface. It can be re-used to quickly predict the acoustic response for any surface vibrations. Similarly, vibro-acoustic transfer vectors (VATV) express the sensitivity of microphone pressures for unit force applied at points on a structure. Also, VATV can be quickly re-used for predicting the acoustic response to any force loading. Modal participation factors (MPFs) can also be used with ATVs in modal acoustic transfer vector (MATV) context.

## Module benefits

- Use ATV to compute noise from rotating machines with multiple revolutions per minute (RPM) loads up to 100 times faster
- Use VATV to quickly evaluate cabin noise due to multiple load cases of flow-induced pressure loads, like wind loads and turbulent boundary layers

## Key features

- ATV results are stored efficiently in a Nastran (op2) or Sysnoise (ssndb) result file
- ATV can be interpolated when used in a forced response context
- Evaluate acoustic pressure and power and panel, grid and modal contributions for ATV response

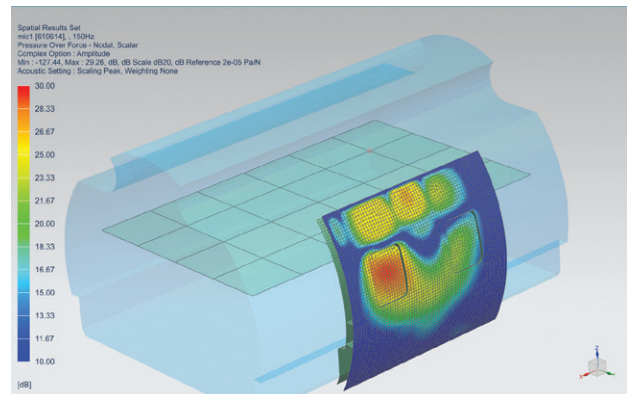
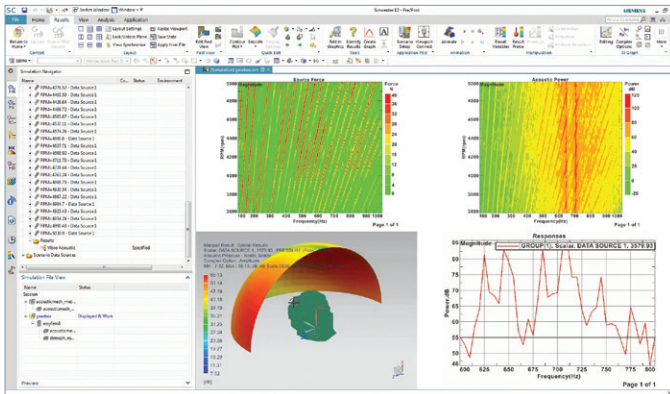

# Simcenter 3D Aero-Vibro-Acoustics

Simcenter 3D Aero-Vibro-Acoustics software supports creating aero-acoustic sources close to noise-emitting turbulent flows and allows you to compute their acoustic response in the exterior or interior environment; for example, for noise from heating, ventilation and air conditioning (HVAC) and environmental control system (ECS) ducts, train boogies and pantographs, cooling fans, ship and aircraft propellers and more. The product also allows you to define wind loads acting on structural panels, leading to a vibro-acoustic response; for instance, in a car or aircraft cabin.

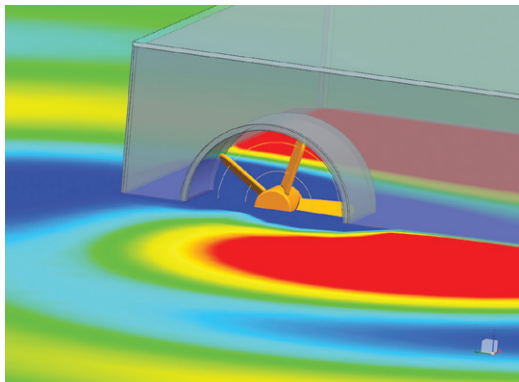
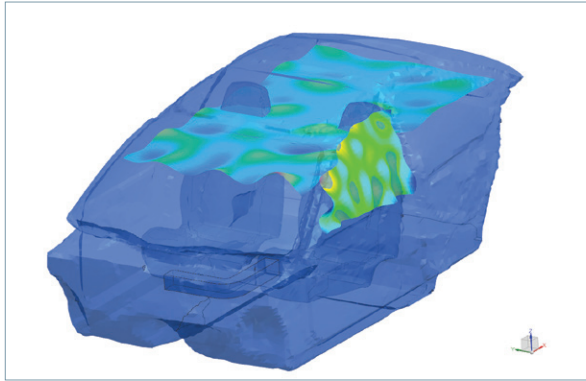

## Module benefits

- Derive lean, surface pressure-based aero-acoustic sources for stationary and rotating surfaces
- Provide scalable and user-friendly load preparation for aero-vibro-acoustic wind noise simulations
- Import binary files with load data directly in Simcenter Nastran for response computation

## Key features

- Conservative mapping of pressure results from CFD to the acoustic or structural mesh
- Equivalent aero-acoustic surface dipole sources
- Equivalent aero-acoustic fan sources for both tonal and broadband noise
- Wind loads, using either semi-empirical turbulent boundary layer models or mapped pressure loads from CFD results

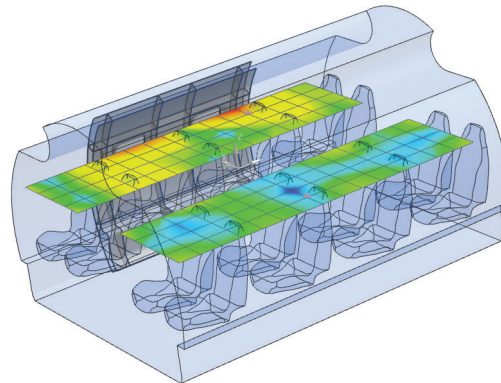



# Simcenter 3D Load Identification

Simcenter 3D Load Identification enables you to get accurate dynamics loadings of a structure. Operational loads are very important for accurate response prediction but are often impossible or difficult to measure directly.

This product offers several ways of identifying the operational forces from measured data, either by mount stiffness method or inverse matrix method. For instance, in an inverse matrix method the operational vibration data can be measured in operational conditions and the transfer functions (FRFs) can be measured in controlled lab conditions or obtained from simulations. These data are then combined in an inverse load identification case.

In addition, Simcenter 3D Load Identification supports a modal expansion solution to create enriched vibration results on a full FE model based on measured vibrations in only a few points.

Finally, a second method to derive structural surface vibrations is provided through inverse numerical acoustics, in which measured pressure responses in only a few points near the structure are used together with acoustic transfer vectors to identify the full surface vibrations. The obtained vibration field can then be used further for acoustic radiation analysis.

## Module benefits

- Determine operational forces or vibrations that are difficult or impossible to measure directly
- Get more realistic simulation by applying more accurate loading
- Combine measured loading data with FE simulations

## Key features

- Mount method to estimate mount forces by combining operational vibration data at each side of the mount and mount stiffness data
- Inverse matrix method by combination of operational measurements and transfer functions based on all measured data or a combination of operation measurements and simulation data
- Straightforward application and re-use of the identified forces or vibrations to the simulation model

## Test



### Mount stiffness method

- Operational vibrations on both ends of the mounts are measured
- Mount stiffness FRFs measured in lab



$$F(\omega) = K(\omega)[X_s(\omega) - X_t(\omega)]$$

### Inverse matrix method

- Operational vibrations are measured
- FRFs measured in lab

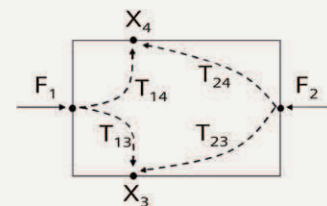

$$\begin{bmatrix} F_1 \\ F_2 \end{bmatrix} = \begin{bmatrix} T_{13} & T_{23} \\ T_{14} & T_{24} \end{bmatrix}^{-1} \begin{bmatrix} X_3 \\ X_4 \end{bmatrix}$$

# Simcenter 3D Environment for BEM Acoustics

Simcenter 3D Environment for BEM Acoustics software supports generating a ready-to-run acoustic or vibro-acoustic simulation model for direct BEM and indirect BEM solvers, and provides comprehensive postprocessing tools to analyze the acoustic or vibro-acoustic results.

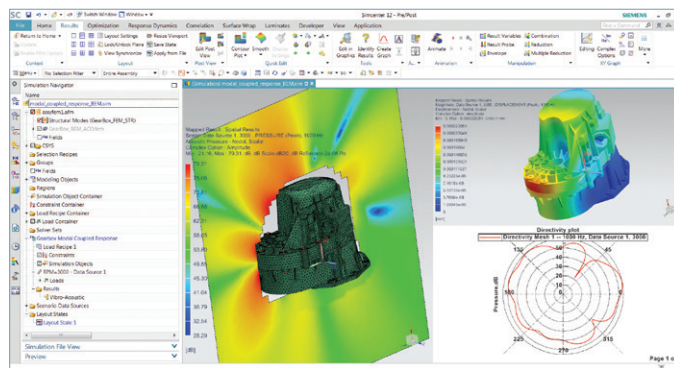
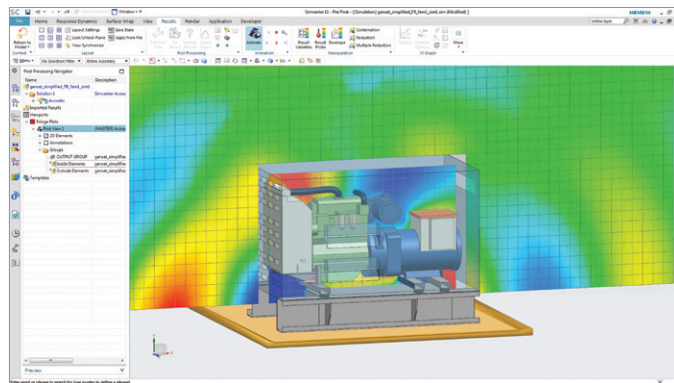

## Module benefits

- Provide a user-friendly interface to streamline acoustic BEM model creation for both standard as well as accelerated BEM solvers
- Support pure acoustic problems as well as weakly or fully coupled vibro-acoustics response via modal-based definition of the structure
- Leverage dedicated postprocessing capabilities to improve users' engineering insight and productivity

## Key features

- Provide all standard structural and acoustic loads and boundary conditions to describe your vibro-acoustic problems accurately
- Prepare deterministic as well as random acoustics and vibro-acoustics analysis
- Standard postprocessing of acoustic results like pressure and acoustic power and structural vibrations
- Dedicated diagnostic plots showing panel contributions and structural modal contributions to the acoustic pressure or power

# Simcenter 3D Acoustics BEM solver

The Simcenter 3D Acoustics BEM solver is used to predict the acoustic response in both enclosed and unbounded domains using a mesh for only the boundary of the fluid domain. Vibro-acoustic analysis is supported by coupling the acoustic fluid with a structural modal model. Structural vibrations can also be imposed on the BEM fluid using weak vibro-acoustic coupling.

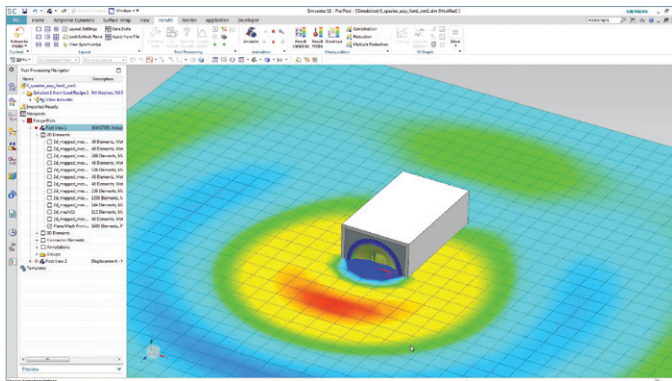
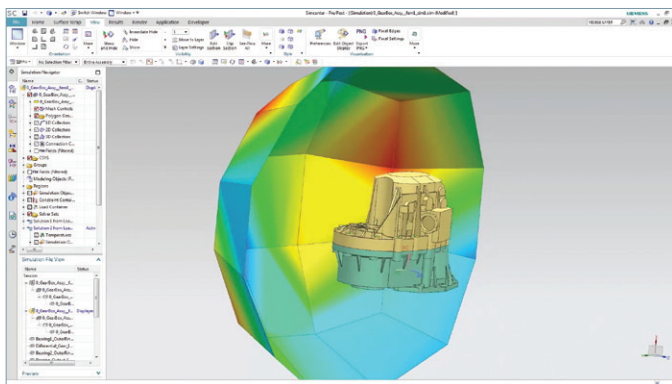

## Module benefits

- Fast and efficient BEM solvers for solving both purely acoustic as well as vibro-acoustic problems
- A multitude of acoustic and structural loads and boundary conditions are supported for an accurate description of your vibro-acoustic simulation model
- Automatic BEM model corrections for free and junction edges

## Key features

- Direct and indirect acoustic uncoupled solutions
- Indirect vibro-acoustic, weakly coupled and strongly coupled solutions
- Deterministic as well as random acoustics and vibro-acoustics analysis
- Returns standard acoustic and structural response results
- Provides structural panel contributions and modal contributions to the acoustic pressure or power

# Simcenter 3D Acoustics Accelerated BEM solver

The Simcenter 3D Acoustics Accelerated BEM software provides hierarchical matrix (H-Matrix) BEM and fast multipole (FM) BEM solvers to extend the computational limits of standard solvers. These solvers are well suited for exterior acoustics of large structures like vehicles and large engines, aircraft, ships, submarines as well as high-frequency applications such as ultrasonic sensors.

## Module benefits

- Provides faster computations for large BEM models (larger geometry and/or higher frequencies)
- Requires lower system memory than standard BEM
- Supports uncoupled acoustics response as well as coupled vibro-acoustics response simulation

## Key features

- Includes an iterative fast multipole solver as well as a direct hierarchical H-Matrix solver
- Both solvers support parallel computing, including up to four processes for free, or using more than four processes when combined with Simcenter 3D Acoustics High Performance Computing (HPC) software
- Supports the convection effect of a (uniform) mean flow on the acoustic wave propagation

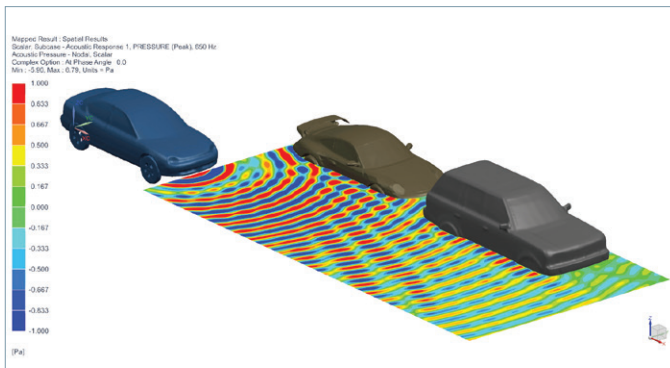
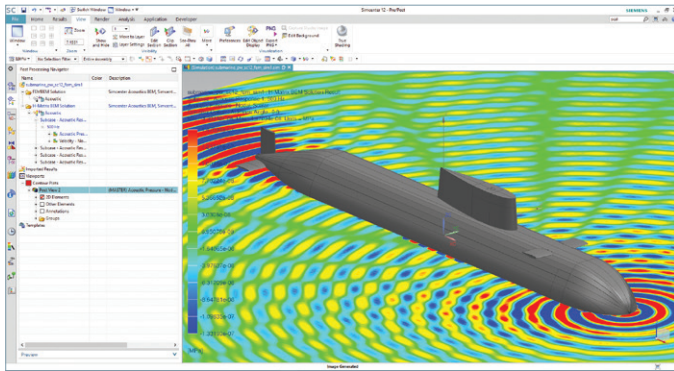

# Simcenter 3D Acoustics Time Domain BEM solver

Simcenter 3D Acoustics Time Domain BEM software enables BEM solutions to solve transient acoustic and vibro-acoustic phenomena. As opposition to the frequency-domain based BEM solvers, Simcenter 3D Acoustics Time Domain BEM Solver gives the possibility to solve problems involving impulsive short time excitation signals in the time domain. This BEM solver is well suited for applications such as parking sensor design and door slam analysis, for instance.

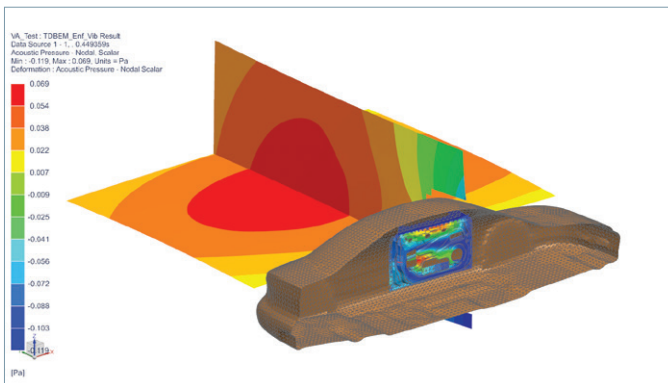
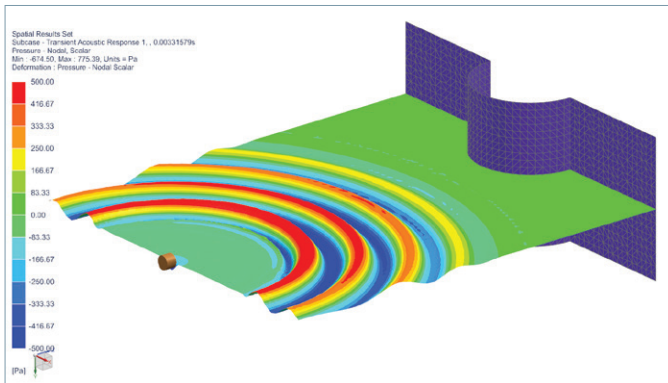

## Module benefits

- Allows for accurate modeling of transient infinite domain problem
- Provides solutions for purely acoustics and vibro-acoustic problems
- Provides fast, efficient solver in time domain, also for large models

## Key features

- Dedicated solver environment Simcenter 3D Acoustics Transient BEM for time-domain BEM computations, including two analysis types: transient acoustic and transient vibro-acoustic
- Supports multiple loads and boundary conditions:
  - Transient acoustic: acoustic monopole, plane wave, infinite plane, acoustic absorber, transfer admittance
  - Transient vibro-acoustic: force applied on structure (with mode set representation), pre-computed vibrations, infinite plane, acoustic absorber, transfer admittance, panel

# Simcenter 3D Acoustics HPC

Simcenter 3D Acoustics HPC software enables you to execute acoustic FEM or BEM computations in multiprocessing mode on the parallel hardware of your choice. Parallel calculation sequences are implemented using the message passing interface (MPI) communication standard. In the case of FEM vibro-acoustics, this product embeds the distributed memory parallelization (DMP) capability of Simcenter Nastran.

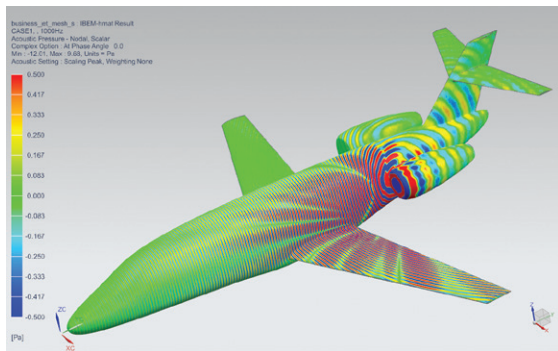
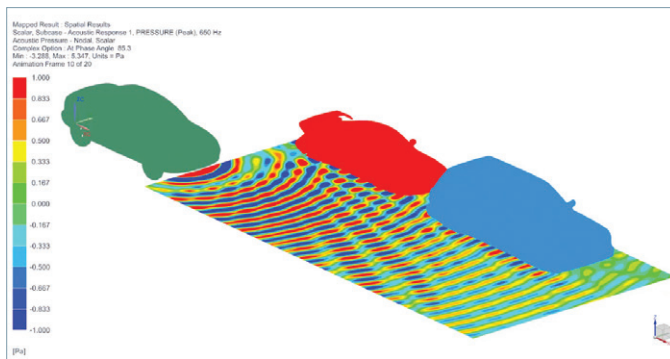

## Module benefits

- Accelerates acoustic computations using multithreading, shared memory parallelization (SMP), multiprocessing and DMP
- This product supports high-performance computing for Simcenter 3D Acoustics FEM and BEM solvers

## Key features

- Solvers can run in high-performance computing mode on multi-node clusters as well as on multi-core workstations
- Allows you to tackle problems with many frequencies with DMP for which a near-linear parallel speed up can be expected

# Simcenter 3D Ray Acoustics

Simcenter 3D Ray Acoustics is used to predict acoustic responses up to very high frequencies and very large geometries, in both enclosed and unbounded domains. Unlike finite element method (FEM) or boundary element method (BEM) acoustic solvers, ray acoustics solutions are not based on a fine discretization of the domain. Therefore, the solution is not bounded by an upper frequency limit or the model size and solving is done orders of magnitude faster as compared to FEM or BEM.

Simcenter 3D Ray Acoustics integrates an engineering environment in Simcenter 3D to generate and postprocess a ray acoustic model, as well as a ray acoustic solver, which is the ICARE solver from CSTB.

## Module benefits

- Solve high-frequency acoustic simulations for large models in a fraction of the time required with FEM or BEM solvers
- A coarse mesh can be used as far as it captures the model geometry, simplifying model creation
- Standard acoustic loads and boundary conditions are supported for an accurate description of the simulation model
- Advanced results and postprocessing to explore ray path arrivals or sound quality criteria

## Key features

- Returns acoustics results both in frequency and time domain
- Simulates the propagation of acoustic wave rays with adaptive beam tracing technology
- Accurately simulates reflections on curved surfaces despite the coarse mesh discretization
- Captures multi-order diffraction effects and creeping waves
- Captures late reflections and diffusion effects with particle tracing technology
- Supports standard acoustic loads including point source directivity

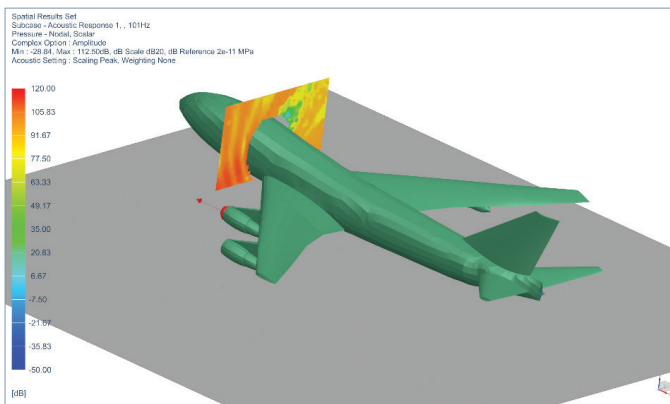
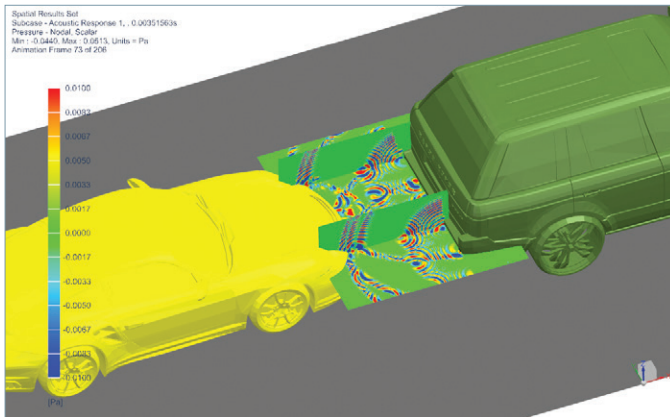

# Capabilities chart

General capabilities	Specific capabilities							FEM acoustics		BEM acoustics						
		Simcenter 3D Meshing for Acoustics	Simcenter 3D Noise and Vibration Modeling *	Simcenter Nastran Basic **	Simcenter Nastran Dynamic Response *	Simcenter Nastran Advanced Dynamics bundle *	Simcenter Nastran Advanced Acoustics	Simcenter 3D Aero-Vibro-Acoustics	Simcenter 3D Environment for BEM Acoustics	Simcenter 3D Acoustics BEM solver	Simcenter 3D Accelerated BEM solver	Simcenter 3D Acoustics Time Domain BEM solver	Simcenter 3D ATV	Simcenter 3D Acoustics HPC	Simcenter 3D Ray Acoustics	Simcenter 3D Load Identification *
Meshing	Surface wrapper mesh for FEM and BEM acoustics	•														
	Convex surface mesher	•														
	2D mesh with thickness (volumize)	•														
	Hybrid meshing for acoustics (tetrahedron and hexahedron)	•														
	Automatic open duct mesh creation	•														
	Generate acoustic envelope from structural mesh	•														
	Cavity meshing	•														
	Coarsener/remesher	•														
	Hole filling	•														
Rib removal	•															
Boundary condition	Acoustics loads: monopoles						•			•						
	Acoustics loads: point source with directionality														•	
	Acoustics loads: plane waves						•			•						
	Acoustics loads: panel normal velocity						•		•							
	Acoustics loads: dipoles, distributed plane waves, enforced acoustic pressure						•		•							
	Aero-acoustic loads: fan source, surface dipoles							•								
	Turbulent boundary layer loads							•								
	Mapped force loads from flow induced loads		•					•								
	Duct modes						•									
	Transfer admittance to model perforated wall/sheet						•		•		•					
	Acoustic absorber (impedance) boundary condition						•			•					•	
	Acoustic continuity to connect different domains						•									
	Infinite plane to represent reflective surfaces						•			•						
	Anechoic nonreflective boundary (AML)						•									
	Anechoic end duct						•									
Convective flow effects						•										



General capabilities	Specific capabilities							FEM acoustics		BEM acoustics						
		Simcenter 3D Meshing for Acoustics	Simcenter 3D Noise and Vibration Modeling *	Simcenter Nastran Basic **	Simcenter Nastran Dynamic Response *	Simcenter Nastran Advanced Dynamics bundle *	Simcenter Nastran Advanced Acoustics	Simcenter 3D Aero-Vibro-Acoustics	Simcenter 3D Environment for BEM Acoustics	Simcenter 3D Acoustics BEM solver	Simcenter 3D Accelerated BEM solver	Simcenter 3D Acoustics Time Domain BEM solver	Simcenter 3D ATV	Simcenter 3D Acoustics HPC	Simcenter 3D Ray Acoustics	Simcenter 3D Load Identification *
Materials	Acoustic fluid							•			•					•
	Porous materials - Craggs, Delany-Bazely-Miki and Jonhson-Champoux-Allard							•								
	Temperature dependent fluid for modeling		•						•							
	Temperature dependent fluid for solving							•								
Representations	Mode set representation		•													
	Mode set response			•							•	•				
	FRF set representation		•													
	FRF set response					•										
	ATV set representation		•													
	ATV set response in Simcenter Nastran											•				
	VATV set representation		•													
	VATV set response in Simcenter Nastran												•			
Solution	ATV, VATV and MATV response in noise and vibration solver		•													
	RDMODES (Recursive domain method for computing structural modes faster)					•										
	Fully/weakly coupled vibro-acoustics with finite element				•											
	Fully/weakly coupled vibro-acoustics with boundary element									•						
	Finite element method acoustics (FEM Acoustics)					•										
	Finite element method adaptive order acoustics (FEMAO Acoustics)						•									
	Acoustics transfer vector analysis (FEM Acoustics and BEM Acoustics)												•			
	Vibro-acoustic transfer vector analysis (FEM Acoustics)												•			
	Modal expansion															•
	Inverse numerical acoustics															•
	Indirect/direct boundary element method acoustics (BEM Acoustics)										•					
	Hierarchical matrix boundary element method (H-matrix BEM)											•				
	Fast multipole boundary element acoustics (FMBEM)												•			
	Transient boundary element method (Transient BEM) acoustics											•				
	Solving up to four parallel processes								•				•			•
	Solving with more than four parallel processes													•		•

General capabilities	Specific capabilities							FEM acoustics		BEM acoustics						
		Simcenter 3D Meshing for Acoustics	Simcenter 3D Noise and Vibration Modeling *	Simcenter Nastran Basic **	Simcenter Nastran Dynamic Response *	Simcenter Nastran Advanced Dynamics bundle *	Simcenter Nastran Advanced Acoustics	Simcenter 3D Aero-Vibro-Acoustics	Simcenter 3D Environment for BEM Acoustics	Simcenter 3D Acoustics BEM solver	Simcenter 3D Accelerated BEM solver	Simcenter 3D Acoustics Time Domain BEM solver	Simcenter 3D ATV	Simcenter 3D Acoustics HPC	Simcenter 3D Ray Acoustics	Simcenter 3D Load Identification *
Postprocessing	Pressure, acoustic velocity and intensity at microphone location and acoustic power		•													
	Contributions of structural modes, panel and grids on the total acoustic response		•													
	Directivity plots		•												•	
	Ray path analysis														•	
	Sound quality criteria														•	

**Legend:**

- If several • are present in a single row, interpret as "OR"
- If several cells are merged with one •, interpret as "AND"
- \* = refer Simcenter 3D for structural dynamics
- \*\* = refer Simcenter 3D for structures

Note: Simcenter 3D Engineering Desktop is a minimum prerequisite for all Simcenter 3D products. Other dependency or prerequisites may apply for individual products.

### **About Siemens Digital Industries Software**

Siemens Digital Industries Software is driving transformation to enable a digital enterprise where engineering, manufacturing and electronics design meet tomorrow. Xcelerator, the comprehensive and integrated portfolio of software and services from Siemens Digital Industries Software, helps companies of all sizes create and leverage a comprehensive digital twin that provides organizations with new insights, opportunities and levels of automation to drive innovation. For more information on Siemens Digital Industries Software products and services, visit [siemens.com/software](https://www.siemens.com/software) or follow us on [LinkedIn](#), [Twitter](#), [Facebook](#) and [Instagram](#). Siemens Digital Industries Software – Where today meets tomorrow.

Headquarters: +1 972 987 3000  
Americas: +1 314 264 8499  
Europe: +44 (0) 1276 413200  
Asia-Pacific: +852 2230 3333

© 2020 Siemens. A list of relevant Siemens trademarks can be found [here](#).  
Other trademarks belong to their respective owners.  
81150-C9 12/20 H